

# H650CS

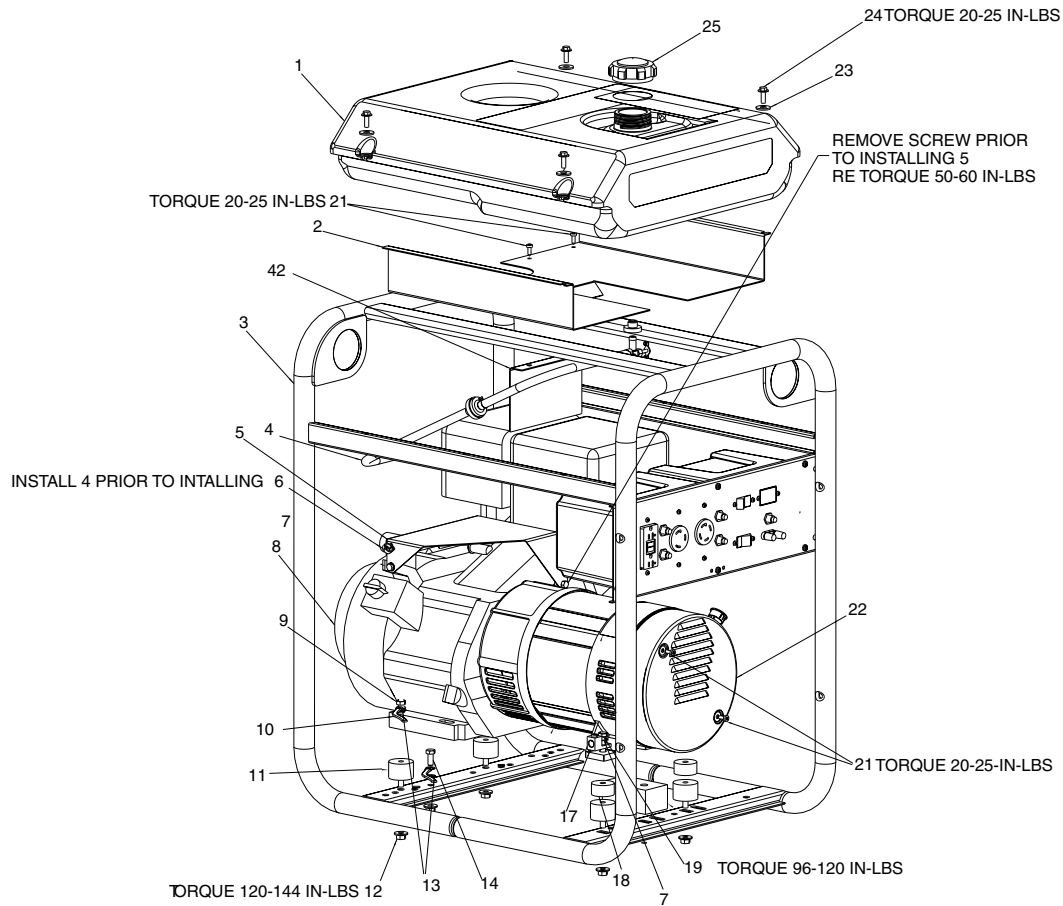

## KEY NO.

## DESCRIPTION

## PART NUMBER

1	TANK FUEL (7 GALLON)	Z-GS-0795
2	SHIELD HEAT	GS-0675
3	FRAME ASSY	Z-D20897
4	HOSE FUEL	Z-GS-0225
5	COVER ENGINE	GS-0676
6	CLIP SNAP-IN FUEL LINE	GS-0763
7	FLAT WASHER	SS-6506-CD
8	ENGINE (Model#GX390K1VD2)	-
9	SCREW HEX CAP 5/16-18 X 1	SSF-605
10	STRAP GROUND	GS-0118
11	ISOLATOR VIBRATION	GS-0033
12	NUT HEX WIZ LOCK LG FLANGE	SSF-8150
13	WASHER LOCK EXTERNAL	SSN-1619-ZN
14	SCREW CAP 5/16-18 X 3/4	SS-12-CD
17	LUG GROUND	GS-0117
18	SPACER 5/16	GS-0492
19	SCREW HEX CAP 5/16-18UNC	95829230
21	SCREW 10-24 X 9/16	SSF-553-1
22	COVER END BLANK	GS-0077
23	WASHER .875 OD .375 ID	SSN-632
24	SCREW 1/4 - 20 X .75	91895680
25	CAP FUEL W/GAUGE	GS-0863
42	BAFFLE HEAT SHIELD	GS-0792

## H650CS (cont'd)

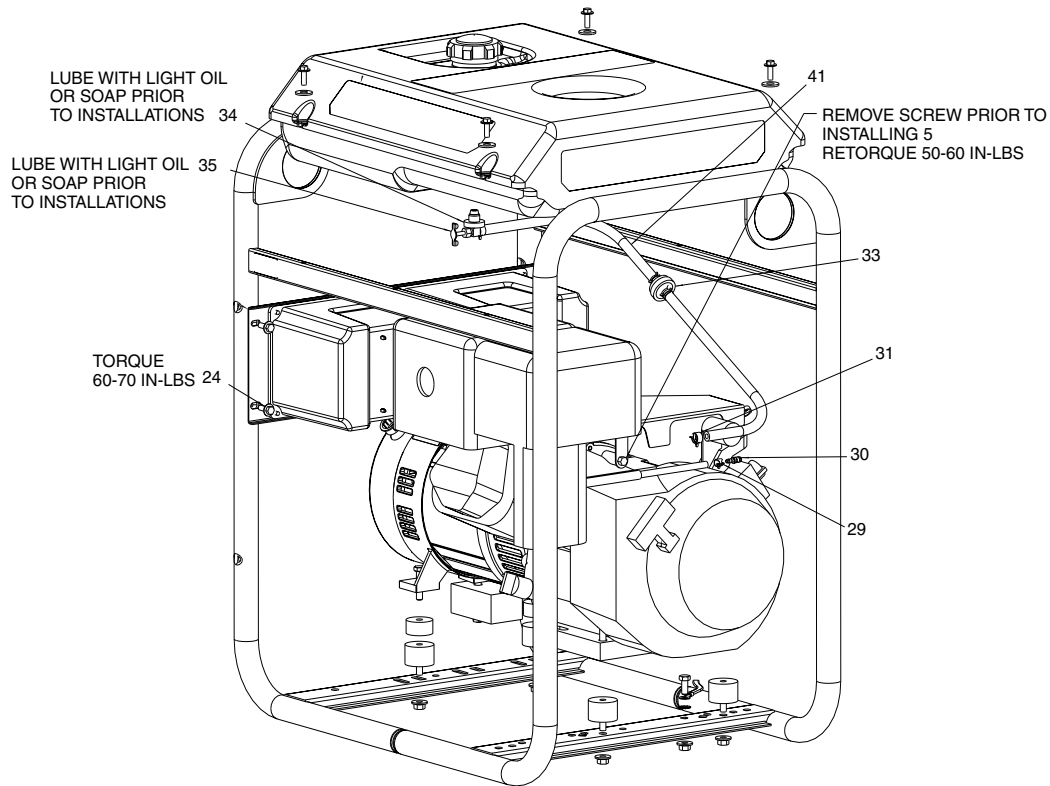

### KEY

<b>NO.</b>	<b>DESCRIPTION</b>	<b>PART NUMBER</b>
24	SCREW 1/4 - 20 X .75	91895680
29	CLAMP HOSE .301 ID	GS-0560
30	UNION REDUCER 1/4 X 3/8	GS-0535
31	CLAMP FUEL .50	GS-0227
33	FILTER FUEL	GS-0459
34	DRAIN COCK GROMMET	GS-0446
35	FUEL SHUTOFF VALVE	GS-0437
41	HOSE FUEL	Z-GS-0225
47	SAFETY CABLE (NOT SHOWN)	GS-0869

## H650CS (cont'd)

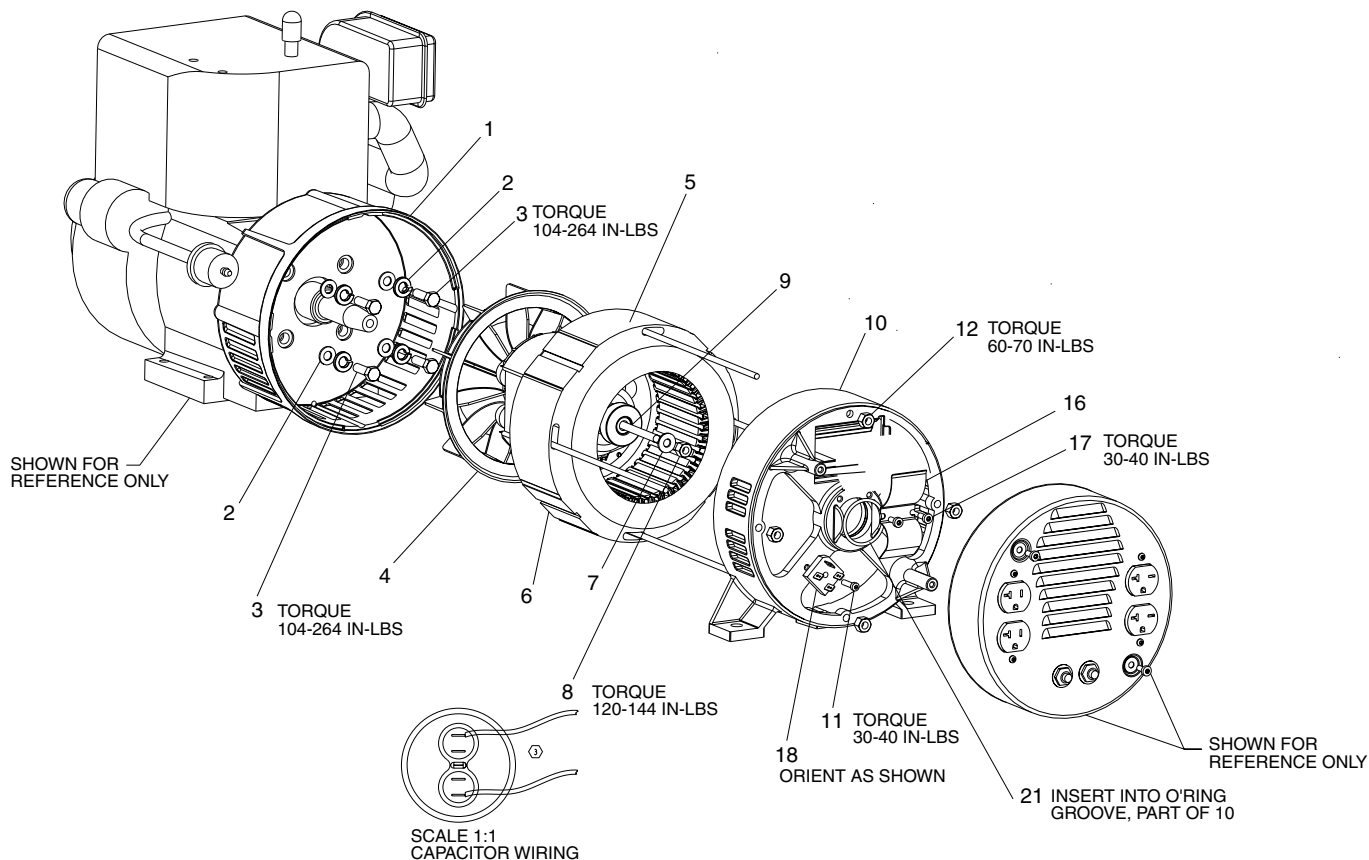

KEY NO.	DESCRIPTION	PART NUMBER
1	ADAPTOR DRIVE END	GS-0076
2	WASHER 3/8 SPLIT LOCK WAS	SSN-619
3	SCREW 3/8" - 16X1 HHS CAP	SSF-577
4	ROTOR ASSY	Z-GS-0860
5	BOLT STATOR THRU	GS-0273
6	STATOR ASSY 207L IDLE	Z-GS-0731
7	WASHER FLAT 11/16 OD X 11	SS-6506-CD
8	NUT 5/16-24 HEX W/KEPS	SSF-576
9	BOLT ROTOR THRU 207L	GS-0315-1
10	BEARING SUPPORT O RING DC	Z-GS-0861
11	SCREW 10-24X.75 T25 TORX	SSF-3158-1
12	NUT 1/4"-20 HEX W/KEPS	SSF-575
16	BRACKET CAPACITOR	GS-0595
17	SCREW 10-24 X 9/16	SSF-553-1
18	RECTIFIER	GS-0767
21	BEARING O-RING	GS-0862

## H650CS (cont'd)

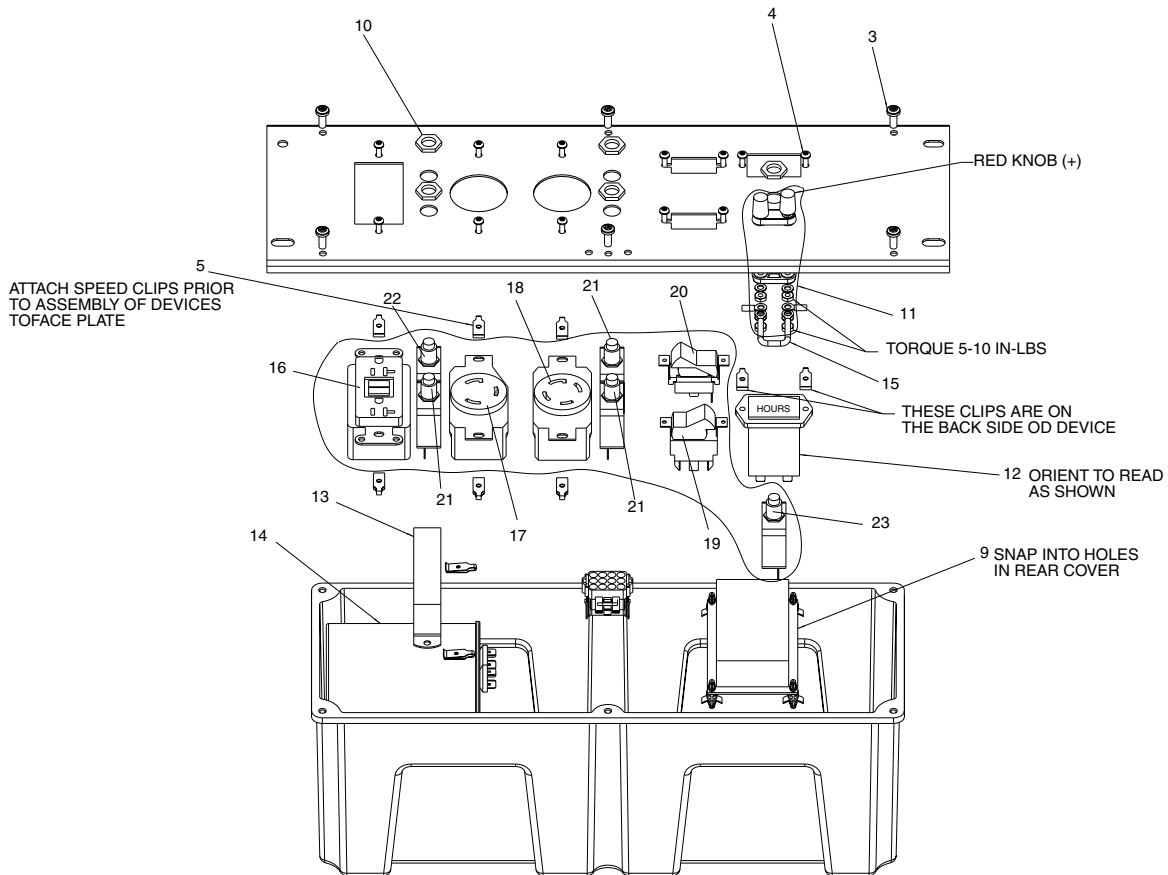

### KEY NO.

### DESCRIPTION

### PART NUMBER

3	SCREW 10-9X.50 PLASTITE	SSF-3156
4	SCREW #6-32 x .5 TORX	SSF-583
5	NUT SPEED #6-32	SSF-584
9	BOARD CIRCUIT ASSY IDLE	GS-0663
10	NUT HEX JAM 7/16	SSF-595
11	BINDING POST ASSY	GS-0728
12	METER HOUR	GS-0735
13	CLAMP CAPACITOR	GS-0756
14	CAPACITOR	GS-0732
15	RESISTOR ASSY DC	GS-0835
16	RECEP GFCI 120V 20A	GS-0644
17	RECEPTACLE 125V 30A SINGLE	GS-0021
18	RECEPTACLE 4 PRONG 30A	GS-0455
19	SWITCH FULL POWER	GS-0045
20	SWITCH IDLE CONTROL	GS-0679
21	CIRCUIT BREAKER 25A	GS-0645
22	CIRCUIT BREAKER 20A	GS-0025
23	CIRCUIT BREAKER 10A	GS-0681

### Not Shown

D21269	Operators Manual
D20891	Parts Manual
GS-0525	Engine Manual